



**EN**

Installation, operation, and maintenance manual  
For installation in hazardous areas

**Flange heater and flange resistor**



**All rights reserved. Reproduction or issue to third parties of this manual or part of it in any form is not permitted without prior written authorisation of the proprietor.**

---

|  |    |
|--|----|
| Safety information .....   | 2  |
| Disclaimer .....   | 3  |
| List of abbreviations .....  | 4  |
| 1.0 Introduction.....  | 5  |
| 2.0 Description of product .....   | 5  |
| 2.1 Flange heater/resistor .....   | 6  |
| 2.2 Hazardous certifications .....   | 6  |
| 3.0 Packing .....  | 7  |
| 3.1 Choice of the Packing Type.....  | 7  |
| 3.2 Wood treatment.....  | 7  |
| 3.3 Pallets.....   | 7  |
| 3.4 Handling .....   | 7  |
| 3.5 Centre of gravity .....  | 7  |
| 3.6 Labelling and tagging of equipment / Identification .....                | 7  |
| 3.7 Shipping marks / labelling .....   | 7  |
| 4.0 Transportation .....   | 8  |
| 4.1 Flange heater / resistor .....   | 8  |
| 5.0 Storage and preservation .....   | 9  |
| 5.1 Preservation during the transportation and pre-installation period ..... | 9  |
| 5.2 Preservation during the installation/construction period .....           | 9  |
| 5.3 Suggestion for preservation specification & record: .....                | 11 |
| 6.0 Installation instructions .....  | 12 |
| 6.1 General .....  | 12 |
| 6.2 Flange heater/resistor installation.....                                 | 12 |
| 7.0 Start up.....  | 14 |
| 7.1 Start-up .....   | 14 |
| 7.2 Before energizing the heating elements .....                             | 14 |
| 7.3 Shutting down the flange heater/resistor .....                           | 15 |
| 8.0 Operating instructions .....   | 16 |
| 9.0 Maintenance instructions.....  | 17 |
| 9.1 Recommended maintenance and service plan.....                            | 18 |
| 10.0 Trouble shooting.....   | 19 |
| 11.0 Disposal instructions .....   | 20 |

## Safety information

In order to secure your personal safety, as well as prevent damages to property, this manual contains notices you have to observe. The notices referring to your personal safety

|  |   |
|--|---|
|  <b>DANGER</b>  | Indicates that death or severe personal injury will result if proper precautions are not taken                  |
|  <b>WARNING</b> | With a safety alert symbol, indicates that minor personal injury can result if proper precautions are not taken |
| <b>CAUTION</b>   | Without a safety alert symbol, indicates that property damage can result if proper precautions are not taken    |
| <b>NOTICE</b>  | Indicates that an unintended result or situation can occur if the corresponding information is not considered   |

*If more than one degree of danger is present, the warning notice representing the highest degree of danger will be used. A notice warning of injury to persons with a safety symbol may also include a warning relating to property damage.*

## Qualified Personnel

Only personnel qualified for the specific task in accordance with the relevant documentation for the specific task, in particular its warning notices and safety instructions may operate the product described in this documentation. Qualified personnel are those who, based on their training and experience, can identify risks and avoiding potential hazards when working with these products/systems.

## Proper use of JEVI products

|  |  |
|--|--|
|  <b>WARNING</b> | Proper transport, storage, installation, assembly, commissioning, operation and maintenance is required to ensure that the product operates safely and without any problems. The permissible ambient conditions must be adhered to. Observe the information in the relevant documentation. |
|--|--|

## **Disclaimer**

JEVI A/S assumes no responsibility for any additions placed by the customer that can inflict our product. Additions or alterations implemented by the customer are not covered by our warranty.

**IMPORTANT:** These instructions should be read thoroughly before installation and operation. All warnings and precautions should be observed for both personal safety and for proper equipment performance and longevity. Failure to follow these instructions could result in equipment failure and/or serious injury to personnel.

**NB! THIS IOM IS A STANDARD DOCUMENT AND IS NOT PROJECT SPECIFIC.**

The English IOM is JEVI's standard version

---

## List of abbreviations

|      |   |
|------|---|
| ACBR | Air Cooled Braking Resistor                                 |
| CoG  | Centre of Gravity   |
| EF   | Electrical Duct heater                                      |
| GA   | General Arrangement (Drawing)                               |
| HVAC | Heating, ventilation, Air Conditioning                      |
| IOM  | Installation, Operating and Maintenance Manual              |
| JB   | Junction Box  |
| VLE  | Fan heater with integrated controls for temperature control |
| VLEx | Fan heater for explosive areas                              |
| WCBR | Water Cooled Braking Resistor                               |
| TSH  | Temperature Switch High                                     |
| TSHH | Temperature Switch High High                                |

## 1.0 Introduction

This manual is valid for flange heaters and flange resistors in hazardous areas.

The purpose of this document is to introduce a reader to installation, operation and maintenance procedure and most importantly to general safety precautions, which are not necessarily related to any specific part or procedure, and do not necessarily, appear elsewhere in the publication. These precautions must be thoroughly understood and applied to in all phases of operation and maintenance.

Descriptions in this manual are generic and are not project specific Pictures may show other equipment and options than in the actual project.

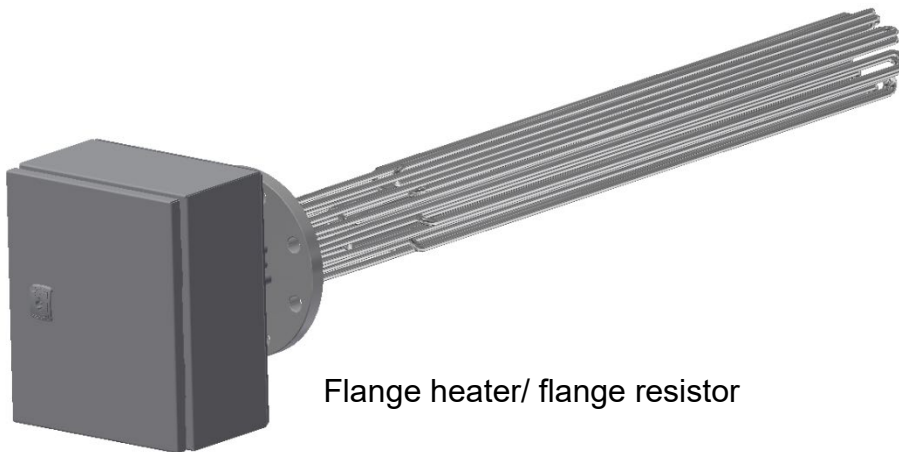

Flange heater/ flange resistor

## 2.0 Description of product

The heaters are designed for heating liquids.

Reference is made to the general drawing of this item for the intended use:

Drawing no. : Refer to equipment drawing GA  
Electric supply : See electrical diagram  
Voltage : See electrical diagram  
Ref. number : Same as order number and item number

### 2.1 Flange heater/resistor

The Flange heater/resistor consists of a certified increased safety “e” enclosure: Type D-8800L, containing:

- Certified electric heating elements (Ex e II).
- Certified Ex e II junction box.
- Certified Ex e II rail mounted terminals and/or copper bars mounted on bus bar support.
- A manually protective rearmable protective device certified Ex db eb IIC Gb or Ex eb ia IIC Gb.

A protective device with manual reset (TSHH). The TSHH is non-adjustable.

In case of no flow the TSHH will cut off the heater.

Optionally the certified equipment mentioned below may be fitted into the junction box:

- Certified Ex ia II C T4-T6 Gb temperature transmitter.
- Certified Ex d II C T4, T5 or T6 Gb anti-condensation heater. Certified Ex d II C T6 Gb or Ex e II T6 Gb control device.

### 2.2 Hazardous certifications

Marking hazardous area certification:

Ex e IIC T6 to T1 with additions d and/or [ia] when applicable.

Standards: EN-IEC 60079-0  
EN-IEC 60079-7  
EN-IEC 60079-1  
EN-IEC 60079-11

ATEX group and category: Ex II 2 G.

Certificate number: IBExU ATEX  
IECEX IBE 16.0018x

## **3.0 Packing**

All packing is in accordance with the specific requirements of the individual purchase order or contract as well as to the regulations of the country of destination.

### **3.1 Choice of the Packing Type**

The choice of the packing type and the requirement of particular protections depend on characteristics of the equipment and material to be packed, its handling requirements and kind of transport chosen.

The packing provides both mechanical and environmental protection.

### **3.2 Wood treatment**

All solid wood, used for packing (including wooden pallets) is treated (heat treatment or fumigation) according to the international standard ISPM 15 (IPPC), latest revision.

As these rules are not the same for all countries, the procedure is to meet the demands of a country of final destination.

### **3.3 Pallets**

Equipment is packed on pallets that provide adequate load support during transportation and storage. The pallets have a dynamic load capacity, enough to carry the mass loaded on the pallet.

Where feasible the top surface of the pallet must be flat.

The pallet must be tight on all sides with steel or synthetic straps on each side.

Bolts, clamps, supporting beams, etc. will properly fix all equipment and materials.

Fragile, easily damageable and loose parts will be pertaining to the equipment securely and properly packed in a separate case.

### **3.4 Handling**

Under no circumstances may the equipment itself be used as a platform for gaining access to installation and construction areas above. If such access is required then suitable scaffolding must be established, the equipment may not be used as a support.

### **3.5 Centre of gravity**

If required, large and heavy equipment are marked with Centre of Gravity (COG).

### **3.6 Labelling and tagging of equipment / Identification**

If no specific identification is required, (see the Purchase Order for the technical specifications) the labeling is in accordance to JEVI standard.

On demand the identification label is in accordance with the final packing list/delivery note.

### **3.7 Shipping marks / labelling**

All packages are marked or labelled in accordance with the data shown in the packing list/delivery note



## 4.0 Transportation

The product is packed according to agreement, with indication of CoG if required by customer.

The product is packed on pallets. The packing is easily moved either by forklift or by use of crane, handled by authorised personnel.

For lifting lugs, see GA

For weight, see GA or rating plate

For COG, see GA

|                |   |
|----------------|---|
| <b>CAUTION</b> | Heating elements must <u>NOT</u> be used for lifting; this causes damage on the elements. |
|----------------|---|

### 4.1 Flange heater / resistor

Lifting lug is welded on the flange.

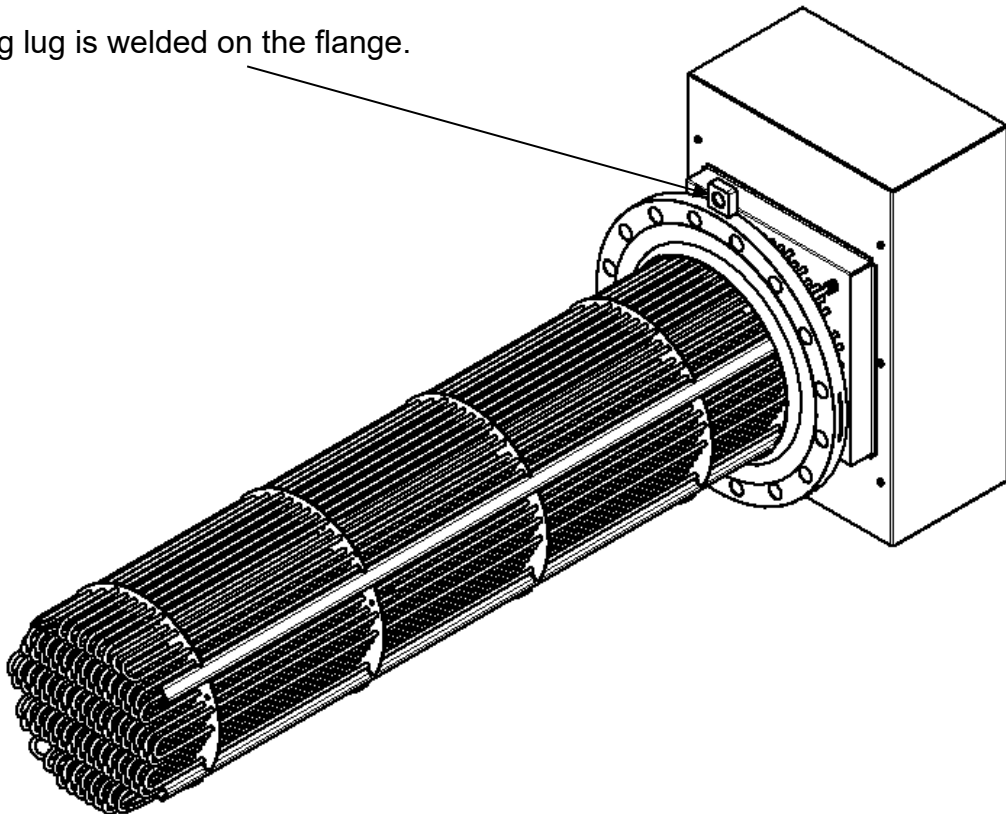

## 5.0 Storage and preservation

The purpose of this chapter is to specify how to handle and preserve a product from the day of shipment until the equipment is installed and commissioned.

**Following conditions shall be observed for the installation/construction period.**

|         |   |
|---------|---|
| CAUTION | During storage, prior to installation the unit must be stored dry with a relative humidity <60 %, temperature >15°C.                |
| CAUTION | Replace desiccant bag in junction boxes and enclosures (if any) every 6 months.<br>Keep a log of the replacements as documentation. |
| CAUTION | The Anti condensation heater, if any, must be powered up and always connected.  |

### 5.1 Preservation during the transportation and pre-installation period

The packaging provides both mechanical and environmental protection. If the equipment is intended for service in an outdoor environment, to avoid any risk of harmful metallic dust during storage it is protected with enveloping plastic foil.  
All openings such as cable entry holes are adequately sealed.

Packages must not be opened, or their integrity disturbed during the transport.  
Packing may only be opened when the equipment has been taken from storage and has been transported to its intended location of installation, or to connect the anti-condensation heater, after which the packing must be resealed. Storage preservation measures are immediately invalidated as soon as the packaging is disturbed.

One shall inspect packages on receipt at the storage warehouse and at regular monthly intervals during the storage period regarding external damages. Any visible damage that may have a consequence to the condition of the contents or integrity of the preservation must be immediately documented and reported. In case of such an event, the supplier must be contacted immediately for advice.

### 5.2 Preservation during the installation/construction period

The product must be unpacked only when the equipment is to be installed, or to connect the anti-condensation heater. It is recommended to maintain the integrity of the packaging during transport from the storage warehouse to the installation site.  
Inspect the equipment within each package for damage and condition as soon as the package is opened. Report and document any damage immediately. In case of such an event, the supplier must be contacted immediately for advice.

Installation and handling of the equipment once unpacked must be performed in accordance with the relevant elements of the documentation for the equipment delivered.

Damages caused by bad workmanship or failure to adhere to the installation instructions are not covered by the equipment warranty.

If the equipment is installed in an area where ongoing construction work of a nature that causes airborne pollution or other adverse conditions take place, the equipment must be suitably protected. Under no circumstances can the equipment be placed in the vicinity of any activity, which involves grinding, welding, painting, fireproofing, spraying, etc. without taking necessary precautions to protect it.

When cable termination is completed, a fresh desiccant bag must be placed in the enclosure. The desiccant bag must be replaced every 6 month or until commissioning, has been initiated.

All openings such as cable entry holes must be adequately sealed until the interfacing cables or pipes are installed.

During installation, always keep the equipment in a clean condition. Remove debris from cable installation activities at once. Take precautions to avoid any small pieces of a conductive nature from being left in the termination enclosures.

Under no circumstances may the equipment itself be used as a platform for gaining access to installation and construction areas above. If such access is required then suitable scaffolding must be established, the equipment may not be used as a support.

During installation the equipment must be thoroughly inspected at regular weekly intervals with regards to external damages, cleanliness and internal condition. Report and document immediately if any visible damage or adverse condition occurs. In case of such an event, the supplier must be contacted immediately for advice.

On completion of the installation work the condition of the equipment must be inspected. Report and document any damage immediately if any visible damage. In case of such an event, the supplier must be contacted immediately for advice.

|         |   |
|---------|---|
| CAUTION | It is extremely important that no debris enters the vessel as this may lead to a blockage of the return, or overflow pipes. |
|---------|---|

**5.3 Suggestion for preservation specification & record:**

| <b>PRESERVATION SPECIFICATION &amp; RECORD</b> |                    |  |                            |                      |                         |                         |                           |                         |  |
|--|--------------------|--|----------------------------|----------------------|-------------------------|-------------------------|---------------------------|-------------------------|--|
| Record No.:                                    |                    | Tag No.:   | Description:               |                      |                         |                         | <b>Record page 1 of 1</b> |                         |  |
| Activity No.:                                  | Intervals (Months) | Description of Preservation Activity   | Recommended Preservative   | Initial Preservation | Date/Sign Preserved (2) | Date/Sign Preserved (3) | Date/Sign Preserved (4)   | Date/Sign Preserved (5) |  |
| 1  | 1                  | Check that protection structure is undamaged.  |                            |                      |                         |                         |                           |                         |  |
| 2  | 6                  | The desiccant bag inside the Junction boxes replaced.  |                            |                      |                         |                         |                           |                         |  |
| 3  | 1                  | Check the storage conditions. Relative humidity < = 60 %, temp. > = 15°C   |                            |                      |                         |                         |                           |                         |  |
| 4  | 12                 | If stored for more than one year from packing date, then the supplier must be contacted for advice regarding renewal of the desiccant bag. |                            |                      |                         |                         |                           |                         |  |
| 5  | 12                 | Check the paintwork.   |                            |                      |                         |                         |                           |                         |  |
| 6  | 12                 | Check that there are no visual damages to the equipment.   |                            |                      |                         |                         |                           |                         |  |
| 7  | 12                 | Verify that the general condition of the equipment is satisfactory.  |                            |                      |                         |                         |                           |                         |  |
| 8  | 12                 | All openings such as cable entry holes are adequately sealed. Junction Boxes as well.  |                            |                      |                         |                         |                           |                         |  |
| 9  | 12                 | All loose items/removed parts preserved, stored and marked.  |                            |                      |                         |                         |                           |                         |  |
| 10   | 6                  | Verify no water leakages, condensation or moisture where applicable.   |                            |                      |                         |                         |                           |                         |  |
| 11   | 6                  | The Anti-condensation heater in the equipment must be powered up and connected at all times.   |                            |                      |                         |                         |                           |                         |  |
| Comments:                                      |                    |  |                            |                      |                         |                         |                           |                         |  |
| Performed by:<br>Date/Sign:                    |                    |  | Accepted by:<br>Date/Sign: |                      |                         |                         |                           |                         |  |

**Note:** These procedures are considered normal maintenance and are performed at the owner's expense.

\* Depending on the environment, inspection frequency can vary.

## 6.0 Installation instructions

### 6.1 General

The user must ensure that his employees are fully trained and supervised in the proper working procedures to ensure their safety. The plant must be maintained in a safe condition.

Ensure that the equipment is correctly installed in a suitable location by technically qualified personnel.

Installation has to meet the requirements of EN/IEC 60079-14.

### 6.2 Flange heater/resistor installation

Before unpacking the equipment ensure that all items are available and that all crates / or packages are in good condition and undamaged. Any damages must be reported to the site manager and subsequently to JEVI A/S.

After removing the packing material, check all items for damage. If any damages; report this to the site manager and subsequently to JEVI A/S.

For installation mounting and sealing materials have to be used which are suitable for the medium to be heated and the prevailing temperatures that will occur. Please refer to the GA-drawing for precise data and indications of fitting positions.

1. Open the junction box, by unlocking the cover with a special key
2. Connect the electric power cables to the terminals or bus bar system as indicated on the electrical diagram and connect the earth provisions on the mounting plate.
3. Connect the protective conductor to the earth terminal.

Size of conductor connection for protective earthing must be according to below.

| Cross-sectional area of phase conductors, S mm <sup>2</sup> | Minimum cross-sectional area of the corresponding PE-conductors, Sp mm <sup>2</sup> |
|---|---|
| S ≤ 16  | S   |
| 16 < S ≤ 35   | 16  |
| S > 35  | 0,5 S   |

4. Follow the instructions provided by the supplier of the cable glands if these are present and/or applicable.
5. Close the cover by using the special key.

---

|   |   |
|---|---|
|  WARNING | Do not open the junction box when energized.  |
| CAUTION   | During storage, prior to installation the unit must be stored dry with a relative humidity <60 %, temperature >15°C.                        |
| CAUTION   | If applicable, connect and switch on the space heater.<br>When dismantled it is advisable to place a desiccant bag inside the junction box. |

## 7.0 Start up

In accordance with EN/IEC 60079-17.

Remove desiccant bag from the junction box before starting up.

### 7.1 Start-up

Before the initial start-up of the flange heater/resistor, the following must be checked:

1. The flange heater/resistor is correctly installed as described in the GA drawing and, if necessary, a leakage test has been performed.
2. The protective conductor (PE) has been connected and, if necessary, the external connection between housing and ground has been effected, e.g. for avoiding electrostatic discharging.
3. The earth connection is effected and properly secured.
4. The electrical connections are performed in accordance with the relevant regulations and wiring schematics.
5. The flange heater/resistor is properly installed, and all studs and nuts are properly tightened.
6. Electrical connections between control panel and immersion heater are correctly installed e.g. power cable, temperature transmitter.

### 7.2 Before energizing the heating elements

1. Check the supply voltage.  
Check the control voltage.  
Voltages are specified on the wiring diagrams of this equipment.
2. Check whether the monitoring system has been actuated e.g. 'Overheat Protection'. (PT100 or thermocouple sensor fixed to an element sheath).
3. Check setting of temperature controller for overheat protection (Temperature setting is stated on wiring diagram)
4. Check setting of temperature controller for medium temperature.

5. Energize the heater elements for approx. 2 minutes and monitor the element skin temperature on the temperature controller. If element skin temperature is not responding shut down the system and check instrumentation and wiring.
6. Run the system on working conditions, e.g. pressure, flow and temperature. Wait until the system has reached the stable temperature and set the overheat protection controller at a level that will cause the heater to trip. If the heater does switch off shut down the system and check for errors.

### 7.3 Shutting down the flange heater/resistor

1. De-energize the flange heater/resistor before shutting down the flow.
2. Re-tighten the stud bolts after the heater has cooled down.



## 8.0 Operating instructions

Before initial start-up of the flange heater/resistor it should be checked whether:

1. The flange heater/resistor is properly installed and, if necessary, a leakage test must be conducted.
2. The electrical connection is performed in accordance with the relevant rules and regulations.
3. The protective conductor (PE) has been connected and, if necessary, the external earth connection between housing and ground has been effected, e.g. for avoiding electrostatic discharge.
4. Monitoring systems have been actuated e.g., “Flow Monitoring” and “Overheat Protection”.
5. The medium to be heated, is in accordance with the heater/resistor design.
6. At the cable entries temperatures exceeding 70°C are not admissible. The minimum temperature rating for all incoming cables is 70°C

|        |  |
|--------|--|
| NOTICE | Before switching on the flange heater/resistor, check that the rated process flow is running.<br>The construction materials used are chosen in accordance with the operating conditions specified.<br>Should the flange heater/resistor be operated with other media or temperatures than those specified, warranty expires immediately! |
|--------|--|

## 9.0 Maintenance instructions

|   |   |
|---|---|
|  <p><b>WARNING</b></p> | Handling of the equipment must meet the requirements of DS/EN 50110-1:2013 (electrical safety). |
|---|---|

In accordance with EN/IEC 60079-17.

The one-year service interval only applies if the flange heater/resistor is installed in a dry and clean environment. If installed in environment which does not meet these requirements, the service intervals might have to be reduced.

The person responsible for the maintenance must ensure that his employees are fully trained and supervised in the proper working procedures to ensure their safety.

1. Check the ceramic insulators on the elements for damage.
2. Check the insulation resistance of the heating elements. Connect the Megger to an earth bolt and one of the phases U1, V1 or W1. If the measured value is less than 2 MΩ, each heating element must be checked separately. Minimum value is 2 MΩ at 1000 volts.
3. Clean all surfaces. On heating elements, salt crystals, carbon or calcium layers must be removed from the sheath of the heating elements by means of a non-metal tool, e.g. wood.
4. Ensure that terminations are securely connected to the terminals or bus bars. Heating element connections are to be tightened properly.
5. Check the function of the space heater in the junction box (if incorporated). The space heater is fitted with an integrated thermostat situated inside the connection cable, which is factory set to frost guard temperatures. The space heater is maintenance free. If the space heater does not function; it must be replaced.

|                      |  |
|----------------------|--|
| <p><b>NOTICE</b></p> | If the insulation resistance has changed because of improper or prolonged storage, it is recommended to:<br>a) open the junction box in a dry area and let the element-connections dry-out using a hot air blower. (note: air<80°C).<br>b) run the flange heater/resistor at a lower voltage until all moisture is evaporated and the insulation resistance has reached its desired value. |
|----------------------|--|

**9.1 Recommended maintenance and service plan**

- Check or clean
- Spare/replacements parts

| System            | Item  | Periodic maintenance interval |                |                 |                 |
|-------------------|---|-------------------------------|----------------|-----------------|-----------------|
|                   |   | Weekly (first 4 weeks)        | Every 6 months | Every 12 months | Every 36 months |
| Whole             | Visual inspection the exterior  | ○                             | ○              | ○               | ○               |
|                   | All nuts and bolts including mounting hardware must be tight                    | ○                             |                | ○               |                 |
| Electrical system | Measurement of Ohm values according to test record (max deviation 10%)          |                               |                | ○               |                 |
|                   | Measurement of insulation resistance <3 m Ohm at 1000 VDC                       |                               |                | ○               |                 |
|                   | Inspect all terminal connections, tighten loose connections                     | ○                             |                | ○               |                 |
|                   | The interiors of each enclosure must be clean, dry and free of foreign material | ○                             |                | ○               | ○               |
|                   | JB cooling fan filters  | ○                             |                |                 |                 |

**Note:** *These procedures are considered normal maintenance and are performed at the owner's expense.*

\* Depending on the environment, inspection frequency can vary.

|                |  |
|----------------|--|
| <b>CAUTION</b> | Fan filter cleaning intervals are strongly dependent on environment. It is recommended to check them on a weekly basis the first 4 weeks and clean them if necessary. If no cleaning was required in initial 4-week period, maintenance interval can be changed to monthly. If in doubt, contact JEVI A/S. |
|----------------|--|

## 10.0 Trouble shooting

|  |  |
|--|--|
|  <b>WARNING</b> | Do not open the junction box when energized. |
|--|--|

Disconnect all power sources prior to any inspection, service, or cleaning. Hazard for electric shock exists while the equipment is connected.

For maintenance requiring repair or replacement of components, contact the factory immediately for further instruction. Only the functions within the scope of normal maintenance are listed below. This manual cannot list all the malfunctions that may occur or the corrective actions that must be carried out. If a malfunction is not listed, contact JEVI A/S.

If there is no heating function do the following:

1. Open the junction box and press the reset button on the TSHH thermal cut-out.
2. Wait for app. 15 minutes and repeat pressing the reset button.
3. Close the junction box.

If this does not remedy the heating function, contact qualified personnel for supervision.

| <b>Problem</b>             | <b>Possible cause</b>                                 | <b>Possible correction</b>  |
|----------------------------|---|---|
| Heater/Resistor failure    | Loose bus bar.<br>Heater/Resistor element burned out. | Tighten failed resistor bank.<br>Disconnect element and use spare.                                |
| Temperature switch trip    | Heater/Resistor over temperature.                     | Ensure air intake and exhaust are clear of foreign particles or blockage.<br>Check fan operation. |
| Pressure differential trip | Loose connections.<br>Intake obstruction.             | Check all connections.<br>Remove and clean.   |

## 11.0 Disposal instructions

Equipment containing electrical components shall not be disposed together with domestic waste. Collect separately with other electrical and electronic waste, according to local legislation.

**JEVI A/S**  
Godthåbsvej 7  
DK-7100 Vejle  
T: +45 75 83 02 11  
[jevi@jevi.dk](mailto:jevi@jevi.dk)  
[www.jevi.com](http://www.jevi.com)

